

DRIVER BITS

OHMI

THE CHART FOR THE PHILLIPS SCREWS NUMBER AND THE DIAMETER

| JCIS Standard Bit | JCIS Standard Small Screws and Tapping |
|-------------------|--|
| No. 0 | M 1.4 ~ M 2.6 |

| JIS Standard Bit | JIS Standard Small Screws and Tapping | Wood Screws |
|------------------|---------------------------------------|-------------|
| No. 1 | M2 - M2.6 (Truss Screw - M3) | 2.1 ~ 2.7 |
| No. 2 | M 3 ~ M 5 | 3.1 ~ 4.8 |
| No. 3 | M 6 ~ M 8 | 5.1 ~ 6.8 |
| No. 4 | | 7.5 ~ 9.5 |

Japan Industrial Standard (JIS B4633) Phillips Screw Driver

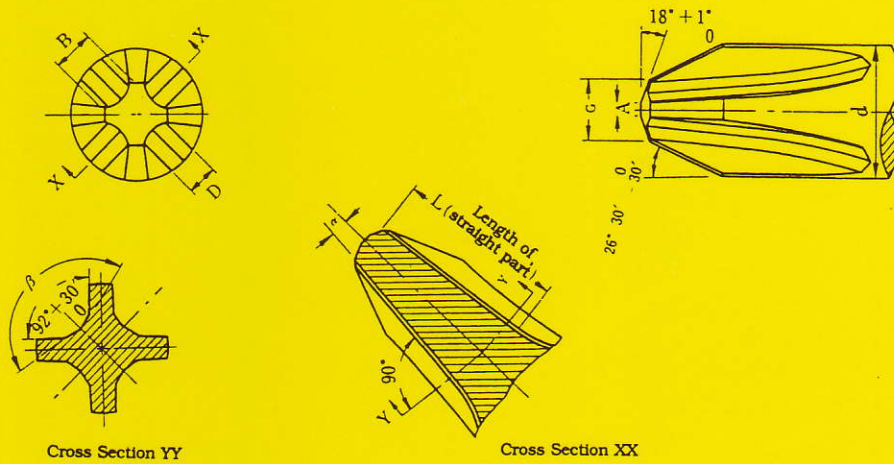

Unit mm

| Size | d | B | G | D | α (2) | β | L | A | |
|-----------------------|--------------|-------------|-------------|-------------|--------------|-----------|---------|---------|---------|
| Screw Diameter number | +0.4 -0.2 | ± 0.025 | ± 0.025 | ± 0.025 | 0 -30' | +30' 0 | Minimum | Maximum | Minimum |
| No. 1 | 5 | 1.001 | 1.27 | 0.513 | 7° | 138° | 3.2 | 0.51 | 0.38 |
| No. 2 | 6 | 1.539 | 2.29 | 1.102 | 5° 45' | 140° | 4.8 | 0.51 | 0.38 |
| No. 3 | 8 | 2.497 | 3.81 | 2.098 | 5° 45' | 146° | 7.1 | 0.51 | 0.38 |
| No. 4 | 9 | 3.574 | 5.08 | 2.738 | 7° | 153° | 8.7 | 0.51 | 0.38 |

Remark: (2) Angle α is an angle to be formed by the forwarding direction of the fraise axis and the center line of the Phillips screw.

Japan Camera Industrial Standard (JCIS 9-70) Phillips Screw for Precision Machinery

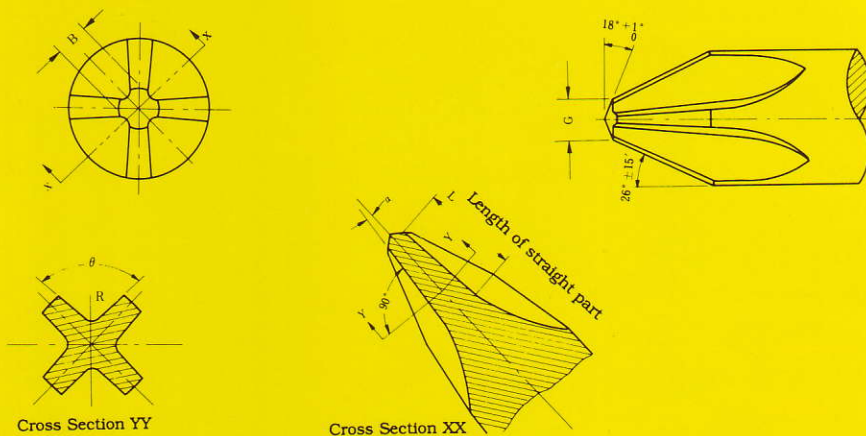

Unit mm

| Type | The Number of Phillips Screw Groove | G | | B | | R | | θ | | α | | L |
|------|-------------------------------------|---------------|------------|---------------|------------|---------------|------------|---------------|-------------|---------------|------------|---------|
| | | Standard size | Allowance | Standard size | Allowance | Standard size | Allowance | Standard size | Allowance | Standard size | Allowance | Minimum |
| I 形 | 0 | 0.93 | ± 0.02 | 0.47 | ± 0.02 | 0.06 | +0.03 0 | 92° | +20' +5' | 7° | 0' -30' | 3 |

OHMI SCREW DRIVER BITS



| Name | Dimension | Tip diameter ($\phi d \times l$) | Point Size | Axis diameter (D) | Total length (L) | Bit name of other company | | | |
|-------|-----------|---------------------------------------|---------------|-----------------------------|------------------------|------------------------------|----------------|-----------------------------|----|
| | | | | | | Vessel | Nitto seiko | | |
| V-17 | | $\phi 2 \times 20l$ | No. 0 | Subtense 6.35mm (1/4) | 50 | | | | |
| | | $\phi 3 \times 30l$ | No. 0 | $\phi 7$ | 75 | U-51 | | | |
| | | $\phi 3.5 \times 30l$ | No. 1 | | 75 | | | | |
| | | $\phi 4.5 \times 30l$ | No. 2 | | 75 | | | | |
| | | | | | 100 | | | | |
| | | | | No. 1 | 23 | U-57 | | | |
| | | | | | No. 2 | | | 30 | |
| | | | | | | | | 40 | |
| | | | | | | | | Subtense 6.35mm (1/4) | 23 |
| | | | | | | | | 30 | |
| | | | | | | | | 40 | |
| | No. 3 | 30 | * 40 | | | | | | |
| | | | | No. 1 | $\phi 7$ | 50 | B-35 | U-50 | |
| | | | | | | 75 | | | |
| | | | | | | 100 | | | |
| | | | | | | 120 | | | |
| | | | | | | 150 | | | |
| | | | | | | 200 | | | |
| * 250 | | | | | | | | | |
| * 300 | | | | | | | | | |
| No. 2 | | | | | | 50 | | | |
| | | | | | | 75 | | | |
| | | | | | | * 90 | | | |
| | | | | | | 100 | | | |
| | | | | | | 120 | | | |
| | | | | | | 150 | | | |
| No. 3 | | | | | | 200 | | | |
| | | | | | | 250 | | | |
| | | | | | | 300 | | | |
| | | | | | | 50 | | | |
| | 75 | | | | | | | | |
| | 100 | | | | | | | | |
| | 120 | | | | | | | | |
| | 150 | | | | | | | | |

| | |
|-------------------|--|
| Applicable driver | <p>Uryu US-5/50/45W/50W/450WB/5W/6W/5PB/10TB/20TB/30TB/40TB/40LTB/50TB US-50T/50TP/LT10B/LT20B/LT30B/LT40B/LT50B/LT60P/3.5MA/4MA/5MA US-4PMA/5PMA/65SPW/350W/5PW/350PW/U-4000/501D/610D/700D UW-6SSLD/6SSD/6SSHD/6SD/ All other UW-UX type drivers</p> <p>Hios F-7000/9000/DL-15/DL-20/DCD-100</p> <p>FujiKuki FW Series/FPW Series/All FD Series</p> <p>Kanon 20. 30. 50.100LTDK/10. 20. 50DPSK ></p> <p>Yokota YD-2.5/3.5/4A/4.5A/4.5LA/5A/5WA/6A/6WA/600A/400A/400CA/500SCA YD-3.5PZ/4.5PA/6PA/8PZ/YW-6PA/6PDA/YHW-4A/V-60A/YD-400SCA YD-5PHCA/5WAZK/6WAZK/3.5PZ/4.5PZ/4.5PT/6PZ/6PT</p> <p>Nitto kohki Please refer to the DV-17 type at page 25</p> <p>Yutani Tekko D-6SSBL/D-6SBPL</p> <p>Japan Pneumatic NPW-450-DXO/NPW-550-DXO</p> <p>Ohmi Seiki BH-3/BH-4A(Bit holder for impact wrench)</p> <p>Tonichi U Series (U-100S/U3/U3V OFF)LTDH/RTDH/RTD/NTD/FTD Series (80FTD/160FTD OFF)</p> |
|-------------------|--|

Please ask us about * marks for their availability



SCREW DRIVER BITS



Exclusive bit for Delvo Electric Driver,
specification by Nitto kohki Co.,Ltd.

| Name | Dimension | Tip diameter ($\phi d \times \ell$) | Drive size | Axis diameter (D) | Total length (L) | Bit name Delvo item No. |
|-------------------|-----------|--|---------------|-------------------------|------------------------|----------------------------|
| V-05B | | $\phi 4$ Straight | H 2.3 | $\phi 4$ | 44 | DLB-2420 |
| | | | H 2.5 | | | DLB-2421 |
| | | $\phi 5 \times 20 \ell$ | H 3 | | | DLB-2422 |
| | | | H 4 | | | DLB-2423 |
| | | | H 4.5 | | | DLB-2424 |
| | | | H 5 | | | DLB-2425 |
| | | | H 5.5 | | | DLB-2426 |
| Applicable driver | Delvo | DLV-6320 / DLV-6330 / DLV-6310 / DLV-6321 / DLV-6331 DLV-7020 / 7030 / 7031 / DLV 8020 / 8030 / 8031 DLV-7312 / 7313 / DLV-7320 / 7321 / 7323 / 7325 / DLV-7330 / 7331 DLV-7319 / 7329 / 7333 / 7335 / 7339 / DLV-3321 / 3331 / 3133 / 3141 / 3151 etc. | | | | |

| | | | | | | |
|-------------------|-------------------|---|----------|----------|----------|----------|
| DV-14 | | $\phi 4 \times 30 \ell$ | No. 1 | $\phi 6$ | 70 | DLB-3120 |
| | | | | | 100 | DLB-3125 |
| | | | | | 70 | DLB-3121 |
| | | | | | 100 | DLB-3127 |
| | | | | | 120 | DLB-3130 |
| | | $\phi 5 \times 30 \ell$ | No. 2 | $\phi 6$ | 70 | DLB-3122 |
| | | | | | 100 | DLB-3126 |
| | | | | | 120 | DLB-3131 |
| | | | | | 70 | DLB-3123 |
| | | | | | 100 | DLB-3128 |
| | $\phi 6$ Straight | No. 1 | $\phi 6$ | 70 | DLB-3124 | |
| | | | | 100 | DLB-3129 | |
| | | | | 120 | DLB-3133 | |
| | | | | 70 | DLB-3128 | |
| | | | | 100 | DLB-3129 | |
| Applicable driver | Delvo | DLV-7120 / 7122 / 7130 / 7132 / 7140 / 7142 / 7220 / 7222 / 7230 / 7231 / 7232 / 7241 / 7242 DLV-8120 / 8122 / 8130 / 8132 / 8140 / 8142 / 8220 / 8222 / 8231 / 8232 / 8241 / 8242 DLV-3121 / 3131 / 3141 / 3151 etc. [Note] For the following auto-feed Delvo, only L-120 of total length can be used. | | | | |

| | | | | | | | |
|-------------------|-------|--|-------|----------|-------|----------|----------|
| DV-17 | | $\phi 7$ Straight | No. 1 | $\phi 7$ | * 50 | DLB-4129 | |
| | | | | | * 75 | DLB-4120 | |
| | | | | | * 100 | DLB-4123 | |
| | | | | | No. 2 | * 50 | DLB-4130 |
| | | | | | | * 75 | DLB-4121 |
| | | | | | | * 50 | DLB-4131 |
| | | | | | No. 3 | * 75 | DLB-4122 |
| | | | | | | | |
| Applicable driver | Delvo | DLV-1130 / 1140 / 1141 / 1150 / 1161 / 1171 DLB-7251 / 7252 / 8150 / 8151 / 8152 / 8251 / 8252 etc. DLL-9020 (Bit type) (this type also usable for double bit) | | | | | |